

# HELI

[www.heliforkliftcanada.com](http://www.heliforkliftcanada.com)

BALANCING ECONOMY WITHOUT COMPROMISING QUALITY.



## FD35P - FD70P

Product specifications

## Pneumatic Tire

## Diesel Forklift

3,500 to 7,000lbs Capacity



**Legendary Heli Quality**

**Productivity & Reliability**

**Powerful Performance**

**Security & Comfort**

**2 Year Limited  
Powertrain Warranty**



**ISO9001**  
ISO 9001 CERTIFICATION

All Heli forklifts meet or exceed  
ASME B56.1 and CSA B335 Standards

**CE**  
CE CERTIFICATION



www.heliforkliftcanada.com



# FD35P - FD70P Diesel

Product specifications

Model		FD 35P	FD 40P	FD 50P	FD 60P	FD 70P
Load Capacity	lbs	3500	4000	5000	6000	7000
Load Center	inches	24"				
Lifting Speed (w load)	fpm	128	108	108	98	61
Travel Max. Speed	mph	9	10.6	10.6	11.2	11.8
Max. Drawbar Pull	lbs	2094/3197	2767/3149	2767/3239	2587/2924	3037/3599
Gradeability @1mph loaded/unloaded	%	29/25	29/25	29/22	26/20	24/20
Tilt Angle (F/B)	degrees	6/12				
Overall Height Fork raised	A inches	170	173	170	179	183.5
Max. Fork Height	B inches	130				
Overall height lowered	C inches	84.4	84.4	84.4	87.4	91.7
Free Lift	E inches	6.1	12.8	12.8	12	12
Overall Length (w fork)	H inches	125.7	139.8	142.5	147.4	148.2
Overall Length (w/o fork)	I inches	89.5	97.6	100.4	105.3	106.1
Min. Under-Clearance	G inches	4.3	4.3	4.3	5.5	5.3
Overhang (Front/Rear)	K/M inches	16.7/17.7	17.7/17	17.7/19.7	18.7/19.7	19.5/19.7
Wheel Base	L inches	55.1	63	63	67	67
Overall Height (w Overhead Guard)	P inches	81.5	81.5	81.5	82.3	82.3
Overall Width	Q inches	42.1	45.3	45.3	48.2	48.2
Opening of Forks	R inches	7.87/37.4	9.6/40.2	9.6/40.2	9.8/41.7	9.8/41.7
Tread (Front/Rear)	S/T inches	36.2/36.2	38.2/38.2	38.2/38.2	39.4/38.2	39.4/38.2
Min. Intersecting Aisle	X inches	70.5	75.6	79.1	83.1	83.1
Min. Turning Radius (Outside)	W inches	78	85.4	88.2	94.5	95.3
Fork size	J/U/F inches	1.5/4/42	1.5/5/42	1.5/5/42	1.75/5/42	1.75/5/42
Engine Model		Kubota V2403				
Rated Horsepower	hp/rpm	47.5/2400			49.6/2600	
Rated Torque		155/1500			160/1700	
Fuel Tank Capacity	Litres	60				
Tire (Front)		6.5-10-10PR	7.0-12-12PR	7.0-12-12PR	28X9-15-12PR	28X9-15-12PR
Tire (Rear)		5.0-8-8PR	6.0-9-10PR	6.0-9-10PR	6.5-10-10PR	6.5-10-10PR
Service Weight	lbs	6204	7502	8294	9614	10,780

## FD35P - FD70P Pneumatic Tire Diesel

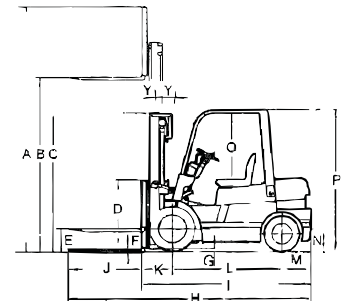
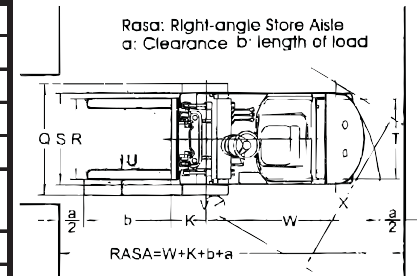

**ISO9001**  
ISO 9001 CERTIFICATION

**CE**  
CE CERTIFICATION

**Options include:**  
 various masts up to 236"  
 sideshifts and attachments  
 full cabs and rainguards  
 air pre-cleaners  
 additional lights

All Heli forklifts meet or exceed ASME B56.1 and CSA B335 Standards

Proud to be your authorized Heli Forklift Canada dealer:

**Heli Forklift Canada**  
 402 Allanburg Rd.  
 Thorold, ON L2V 1A4  
 1-877-435-4352 905-227-3291  
 www.heliforkliftcanada.com  
 sales@heliforkliftcanada.com